

# CON-E-CO®

An Oshkosh Corporation Company



## **LO-PRO®** **SPECIFICATIONS**

**Models 5, 10, 12, 12N, 12RS, 250,  
327, 327CM, 427, 427CM**

**SOLID PRODUCTS. SOLID PERFORMANCE.**

# LO-PRO® Model 5

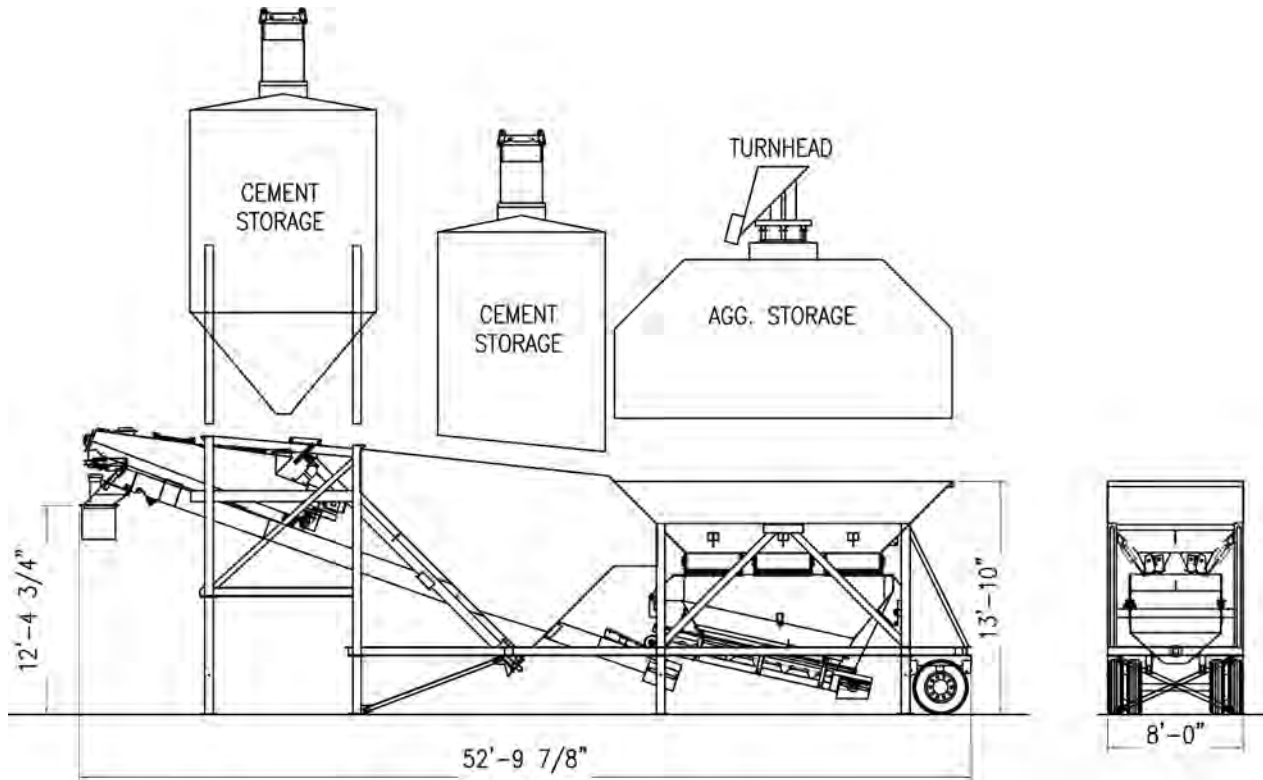

## SPECIFICATIONS

### PRODUCTION CAPACITY:

Theoretical Cycle Time – 2.5 to 3 minutes

### BATCHER CAPACITY:

Aggregate – 1 to 5 cubic yards (1 to 3.8 cubic meters)  
 Cement – 1 to 5 cubic yards (1 to 3.8 cubic meters)  
 Scales – Direct load cells

### AGGREGATE BATCHER CONVEYOR:

24" wide (610 mm), 10 horsepower drive.

### AGGREGATE DISCHARGE CONVEYOR:

24" wide (610 mm), 10 horsepower drive.

### CEMENT BATCHER RECIRCULATING SCREW:

12" diameter (305 mm), 10 horsepower

### CEMENT FEEDER SCREWS:

Two each - 6" diameter (152 mm), 10 horsepower drive

### CEMENT AERATION:

5 horsepower, high volume, low pressure blower.

### HIGH PRESSURE AIR COMPRESSOR:

10 horsepower with 80 gallon (0.30 cubic meters) receiver. Optional 15 horsepower, 80 gallon (0.30 cubic meters).

### ELECTRICAL:

460 volt, 3-phase with 120 VAC transformer for control voltage. All motors are TEFC. All motor circuit wiring protected by individual circuit breakers. Electrical components housed in NEMA steel enclosures. Wiring in conduit.

### BATCH CONTROL SYSTEM:

Semi-automatic cut-off of cement by presets on digital readouts. Push-

button for electric over air on gates. Optional fully automatic computerized batch control system.

### WATER METER:

3" diameter (77 mm) with up to 500 gallons (1,740 liters) per minute.

### TRANSPORTATION SYSTEM:

Rear-mounted 19,000 lb. (9,090 kg) capacity single axle with four (4) 295/75R 22.5 tires, air brakes heavy duty spring suspension, and fifth wheel rub plate with king pin.

### STORAGE BIN CAPACITIES:

AGGREGATE	HEAPED VOLUME
	26 to 86 cubic yards
	19 to 65 cubic meters

CEMENT I	GROSS VOLUME
	716 to 2,360 cubic feet
	20 to 66 cubic meters

CEMENT II	GROSS VOLUME
	1,600 cubic feet
	45 cubic meters

### DIMENSIONS:

Towing length.....	45'3" (13,790 mm)
Towing height.....	14'2" (4,318 mm)
Towing width.....	8'0" (2,440 mm)
Empty weight, total.....	37,600 lbs. (17,091 kg)

### SHIPPING DIMENSIONS:

Length .....	54'0" (16,460 mm)
Height .....	14'2" (4,318 mm)
Width .....	8'0" (2,439 mm)
Shipping volume.....	6,118 cubic feet (173 cubic meters)

# LO-PRO® Model 10

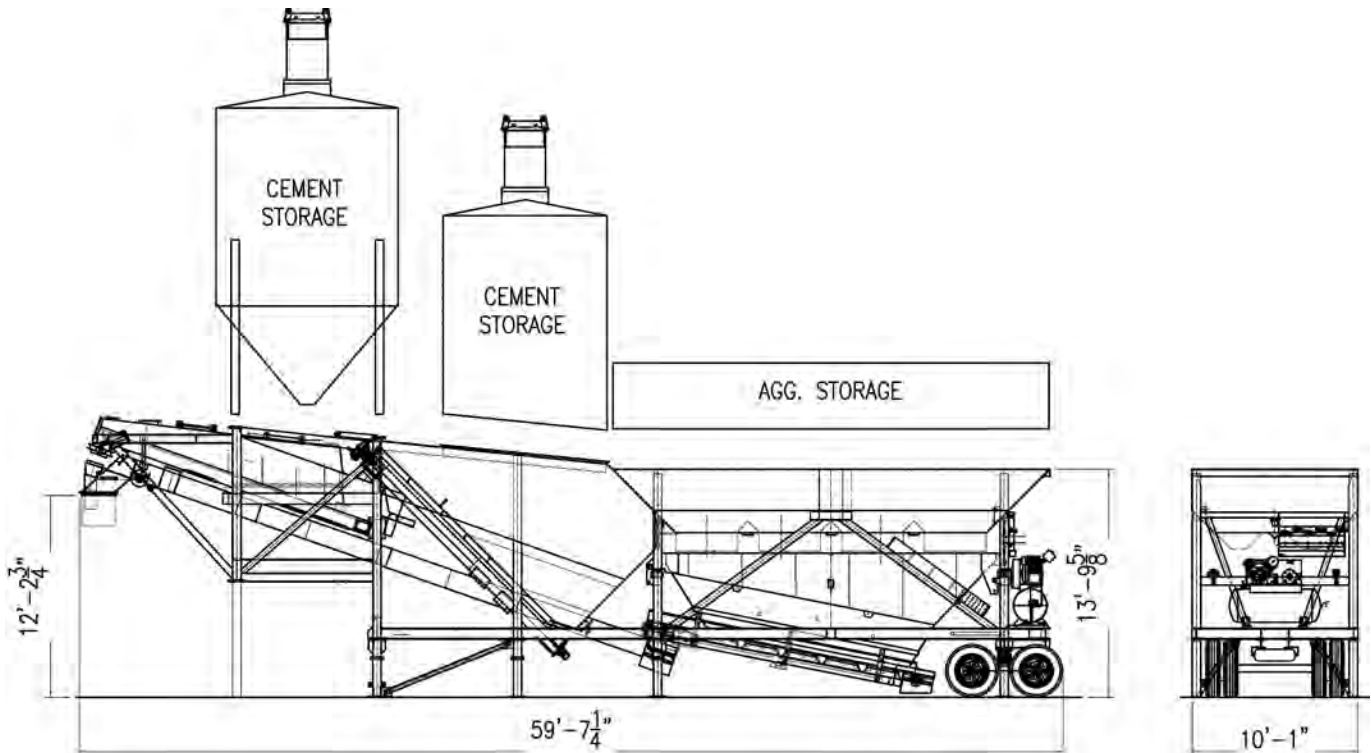

## SPECIFICATIONS

### PRODUCTION CAPACITY:

Theoretical Cycle Time – 2.5 to 3 minutes

### BATCHER CAPACITY:

Aggregate – 1 to 10 cubic yards (1 to 7.6 cubic meters)

Cement – 1 to 10 cubic yards (1 to 7.6 cubic meters)

Scales – Direct load cells

### AGGREGATE BATCHER CONVEYOR:

30" wide (762 mm), 10 horsepower drive.

Optional 15 horsepower drive.

### AGGREGATE DISCHARGE CONVEYOR:

30" wide (762 mm), 35° trough with 10 horsepower drive. Optional 36" (914 mm), 15 horsepower

### CEMENT BATCHER RECIRCULATING SCREW:

14" diameter (360 mm), 15 horsepower

Optional 18" diameter (460 mm), 20 horsepower

### CEMENT FEEDER SCREWS:

Two 9" diameter (230 mm), 15 horsepower drive. Optional 12" diameter (300 mm), 20 horsepower.

### CEMENT AERATION:

5 horsepower, high volume, low pressure blower.

### HIGH PRESSURE AIR COMPRESSOR:

10 horsepower, 120 gallon (0.45 cubic meters). Optional 15, 20, 25 or 30 horsepower, 120 gallon (0.45 cubic meters).

### ELECTRICAL:

460 volt, 3-phase with 120 VAC transformer for control voltage. All motors are TEFC. All motor circuit wiring protected by individual circuit breakers. Electrical components housed in NEMA steel enclosures. Wiring in conduit.

### BATCH CONTROL SYSTEM:

Semi-automatic cut-off of cement by presets on digital readouts. Push-button for electric over air on gates. Optional fully automatic computerized batch control system.

### WATER METER:

3" diameter (77 mm) with up to 500 gallons (1,740 liters) per minute.

### TRANSPORTATION SYSTEM:

Rear-mounted 36,000 lb. (16,330 kg) capacity tandem axle with eight (8) 295/75R 22.5 tires, wheels, air brakes heavy duty spring suspension, tail and brake lights, and fifth wheel rub plate with king pin.

### STORAGE BIN CAPACITIES:

AGGREGATE	HEAPED VOLUME
	50 to 92 cubic yards
	38 to 70 cubic meters
CEMENT I	GROSS VOLUME
	940 to 2,940 cubic feet
	26 to 83 cubic meters
CEMENT II	GROSS VOLUME
	1,600 to 2,940 cubic feet
	45 to 83 cubic meters

### DIMENSIONS:

Towing length.....50'0" (15,240 mm)  
 Towing height.....14'3" (4,345 mm)  
 Towing width.....10'1" (3,073 mm)  
 Empty weight, total.....44,000 lbs. (19,958 kg)

### SHIPPING DIMENSIONS:

Length ..... 61'0" (18,593 mm)  
 Height ..... 14'3" (4,345 mm)  
 Width ..... 10'1" (3,073 mm)  
 Shipping volume.....8,764 cubic feet (248 cubic meters)

# LO-PRO® Model 12

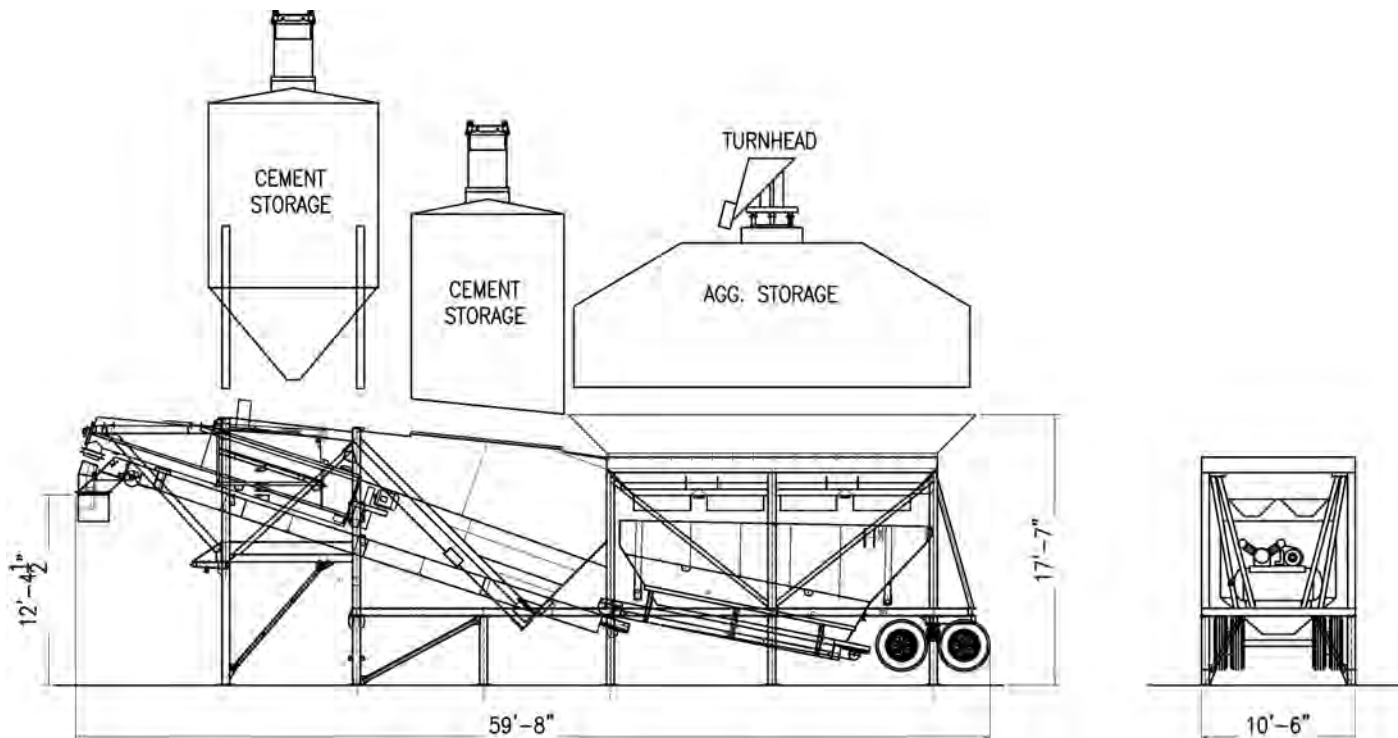

## SPECIFICATIONS

### PRODUCTION CAPACITY:

Theoretical Cycle Time – 2.5 to 3 minutes

### BATCHER CAPACITY:

Aggregate – 1 to 12 cubic yards (1 to 9.2 cubic meters)

Cement – 1 to 12 cubic yards (1 to 9.2 cubic meters)

Scales – Direct load cells

### AGGREGATE BATCHER CONVEYOR:

30" wide (762 mm), 10 horsepower drive. Optional 15 horsepower drive

### AGGREGATE DISCHARGE CONVEYOR:

30" wide (762 mm), 35" trough with 10 horsepower drive. Optional 36" (914 mm), 15 horsepower or 20 horsepower

### CEMENT BATCHER RECIRCULATING SCREW:

14" diameter (360 mm), 15 horsepower

Optional 18" diameter (460 mm), 20 horsepower

### CEMENT FEEDER SCREWS:

Two 9" diameter (230 mm), 15 horsepower drive. Optional 12" diameter (300 mm), 20 horsepower.

### CEMENT AERATION:

5 horsepower, high volume, low pressure blower.

### HIGH PRESSURE AIR COMPRESSOR:

10 horsepower, 120 gallon (0.45 cubic meters). Optional 15, 20, 25, or 30 horsepower, 120 gallon (0.45 cubic meters).

### ELECTRICAL:

460 volt, 3-phase with 120 VAC transformer for control voltage. All motors are TEFC. All motor circuit wiring protected by individual circuit breakers. Electrical components housed in NEMA steel enclosures. Wiring in conduit.

### BATCH CONTROL SYSTEM:

Semi-automatic cut-off of cement by presets on digital readouts. Push-button for electric over air on gates. Optional fully automatic computerized batch control system.

### WATER METER:

3" diameter (77 mm) with up to 500 gallons (1,740 liters) per minute.

### TRANSPORTATION SYSTEM:

Rear-mounted 36,000 lb. (16,330 kg) capacity tandem axle with eight (8) 295/75R 22.5 tires, wheels, air brakes heavy duty spring suspension, tail and brake lights, and fifth wheel rub plate with king pin.

### STORAGE BIN CAPACITIES:

AGGREGATE	HEAPED VOLUME
	59 to 270 cubic yards
	45 to 200 cubic meters
CEMENT I	GROSS VOLUME
	940 to 2,940 cubic feet
	26 to 83 cubic meters
CEMENT II	GROSS VOLUME
	1,600 to 4,920 cubic feet
	45 to 139 cubic meters

### DIMENSIONS:

Towing length.....	51'0" (15,545 mm)
Towing height.....	14'3" (4,345 mm)
Towing width.....	10'6" (3,200 mm)
Empty weight, total.....	44,000 lbs. (19,958 kg)

### SHIPPING DIMENSIONS:

Length .....	61'0" (18,593 mm)
Height .....	14'3" (4,345 mm)
Width .....	10'6" (3,200 mm)
Shipping volume.....	9,127 cubic feet (258 cubic meters)

# LO-PRO® Model 12N

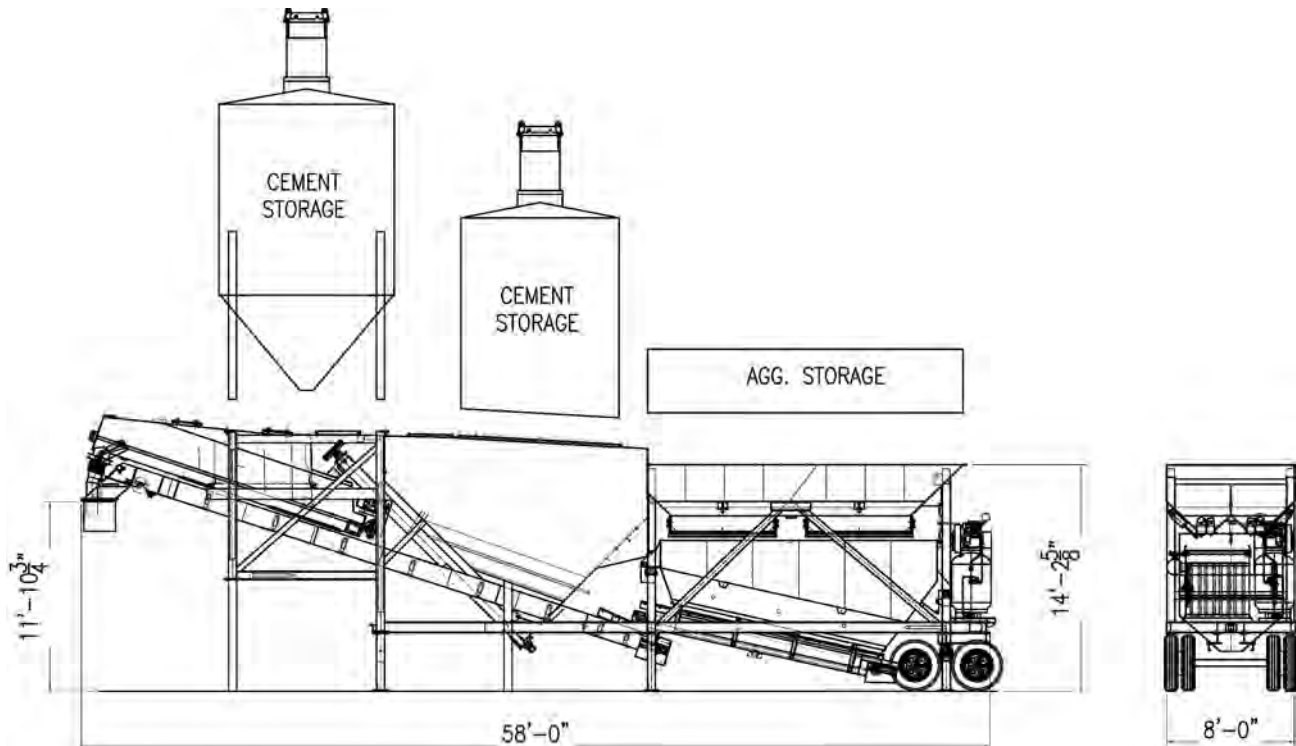

## SPECIFICATIONS

### PRODUCTION CAPACITY:

Theoretical Cycle Time  
 (2) 6" screws — 6 minutes  
 (2) 9" screws — 5 minutes

### BATCHER CAPACITY:

Aggregate — 1 to 12 cubic yards (1 to 9.2 cubic meters)  
 Cement — 1 to 12 cubic yards (1 to 9.2 cubic meters)  
 Scales — Direct load cells

### AGGREGATE BATCHER CONVEYOR:

24" wide (610 mm), 10 horsepower drive.

### AGGREGATE DISCHARGE CONVEYOR:

24" wide (610 mm), 35° trough with 10 horsepower drive. Optional 30" (762 mm), 35° trough with 15 horsepower drive.

### CEMENT BATCHER RECIRCULATING SCREW:

14" diameter (360 mm), 15 horsepower

### CEMENT FEEDER SCREWS:

Two 6" diameter (153 mm), 10 horsepower. Optional (2) 9" diameter (230 mm), 15 horsepower.

### CEMENT AERATION:

5 horsepower, high volume, low pressure blower.

### HIGH PRESSURE AIR COMPRESSOR:

7.5 horsepower, 80 gallon (0.35 cubic meters). Optional 10 or 15 horsepower, 120 gallon (0.45 cubic meters).

### ELECTRICAL:

460 volt, 3-phase with 120 VAC transformer for control voltage. All motors are TEFC. All motor circuit wiring protected by individual circuit breakers. Electrical components housed in NEMA steel enclosures. Wiring in conduit.

### BATCH CONTROL SYSTEM:

Semi-automatic cut-off of cement by presets on digital readouts. Push-button for electric over air on gates. Optional fully automatic computerized batch control system.

### WATER METER:

3" diameter (77 mm) with up to 500 gallons (1,740 liters) per minute.

### TRANSPORTATION SYSTEM:

Rear-mounted 36,000 lb. (16,330 kg) capacity tandem axle with eight tires, wheels, air brakes heavy duty spring suspension, tail and brake lights, and fifth wheel rub plate with king pin.

### STORAGE BIN CAPACITIES:

AGGREGATE	HEAPED VOLUME
	25 to 36 cubic yards 19 to 27 cubic meters
CEMENT I	GROSS VOLUME
	800 to 1,500 cubic feet 22 to 42 cubic meters
CEMENT II	GROSS VOLUME
	1,600 cubic feet 45 cubic meters

### DIMENSIONS:

Towing length.....50'0" (15,545 mm)  
 Towing height.....14'4" (4,369 mm)  
 Towing width.....8'0" (2,439 mm)  
 Empty weight, total..... 44,000 lbs. (19,958 kg)

### SHIPPING DIMENSIONS:

Length ..... 58'9" (18,593 mm)  
 Height ..... 14'4" (4,369 mm)  
 Width ..... 8'0" (2,439 mm)  
 Shipping volume..... 6,737 cubic feet (191 cubic meters)

# LO-PRO® Model 12RS

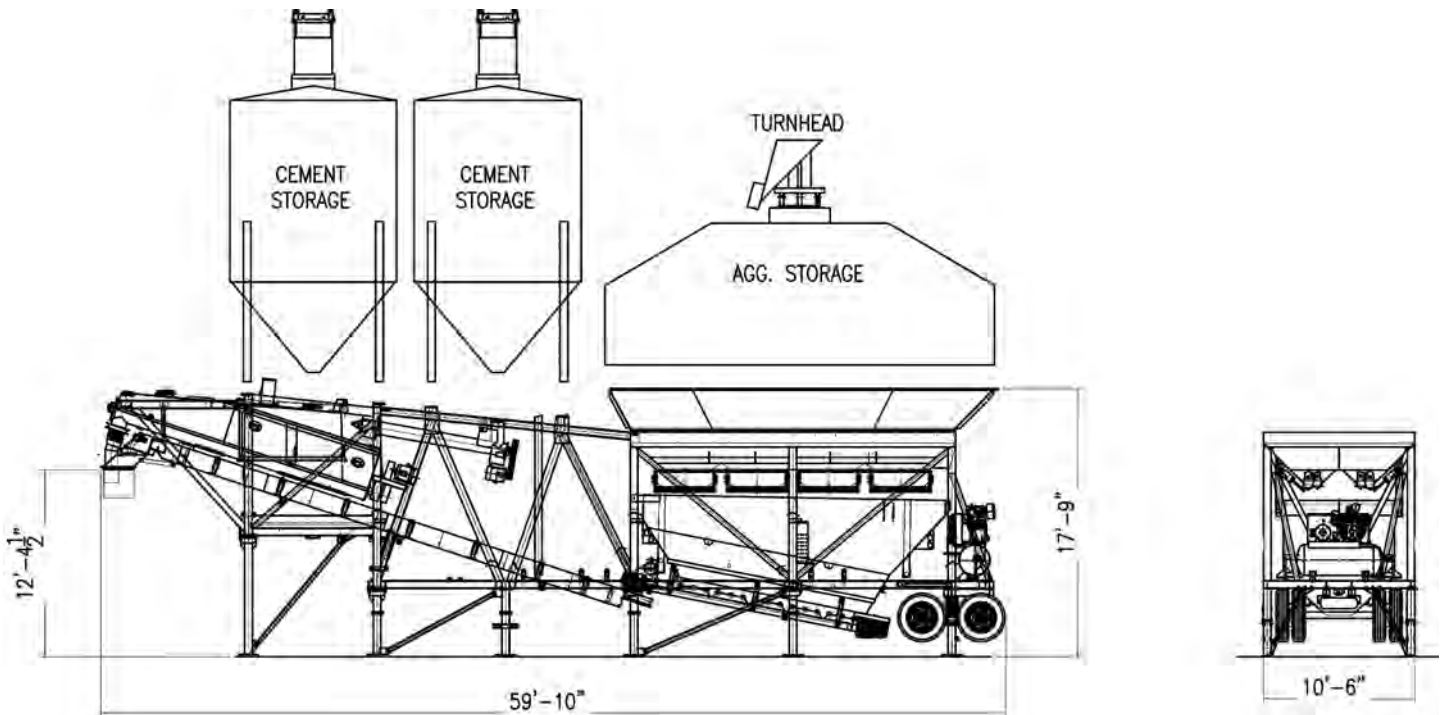

## SPECIFICATIONS

### PRODUCTION CAPACITY:

Theoretical Cycle Time – 2.5 to 3 minutes

### BATCHER CAPACITY:

Aggregate – 1 to 12 cubic yards (1 to 9.2 cubic meters)

Cement – 1 to 12 cubic yards (1 to 9.2 cubic meters)

Scales – Direct load cells

### AGGREGATE BATCHER CONVEYOR:

30" wide (762 mm), 10 horsepower drive. Optional 15 horsepower drive

### AGGREGATE DISCHARGE CONVEYOR:

30" wide (762 mm), 35" trough with 10 horsepower drive. Optional 36" (914 mm), 15 horsepower

### CEMENT BATCHER RECIRCULATING SCREW:

14" diameter (360 mm), 15 horsepower

Optional 18" diameter (460 mm), 20 horsepower

### CEMENT II FEEDER SCREW:

9" diameter (230 mm), 15 horsepower drive. Optional 12" diameter (300 mm), 20 horsepower.

### CEMENT AERATION:

5 horsepower, high volume, low pressure blower.

### HIGH PRESSURE AIR COMPRESSOR:

10 horsepower, 120 gallon (0.45 cubic meters). Optional 15, 20, 25, or 30 horsepower, 120 gallon (0.45 cubic meters).

### ELECTRICAL:

460 volt, 3-phase with 120 VAC transformer for control voltage. All motors are TEFC. All motor circuit wiring protected by individual circuit breakers. Electrical components housed in NEMA steel enclosures. Wiring in conduit.

### BATCH CONTROL SYSTEM:

Semi-automatic cut-off of cement by presets on digital readouts. Push-button for electric over air on gates. Optional fully automatic computerized batch control system.

### WATER METER:

3" diameter (77 mm) with up to 500 gallons (1,740 liters) per minute.

### TRANSPORTATION SYSTEM:

Rear-mounted 36,000 lb. (16,330 kg) capacity tandem axle with eight (8) 295/75R 22.5 tires, wheels, air brakes heavy duty spring suspension, tail and brake lights, and fifth wheel rub plate with king pin.

### STORAGE BIN CAPACITIES:

AGGREGATE	HEAPED VOLUME
	59 to 270 cubic yards
	45 to 200 cubic meters
CEMENT I	GROSS VOLUME
	1,600 to 4,920 cubic feet
	45 to 139 cubic meters
CEMENT II	GROSS VOLUME
	1,600 to 4,920 cubic feet
	45 to 139 cubic meters

### DIMENSIONS:

Towing length.....	51'0" (15,545 mm)
Towing height.....	14'3" (4,345 mm)
Towing width.....	10'6" (3,200 mm)
Empty weight, total.....	44,000 lbs. (19,958 kg)

### SHIPPING DIMENSIONS:

Length .....	61'0" (18,593 mm)
Height .....	14'3" (4,345 mm)
Width .....	10'6" (3,200 mm)
Shipping volume.....	9,127 cubic feet (258 cubic meters)

# LO-PRO® Model 250

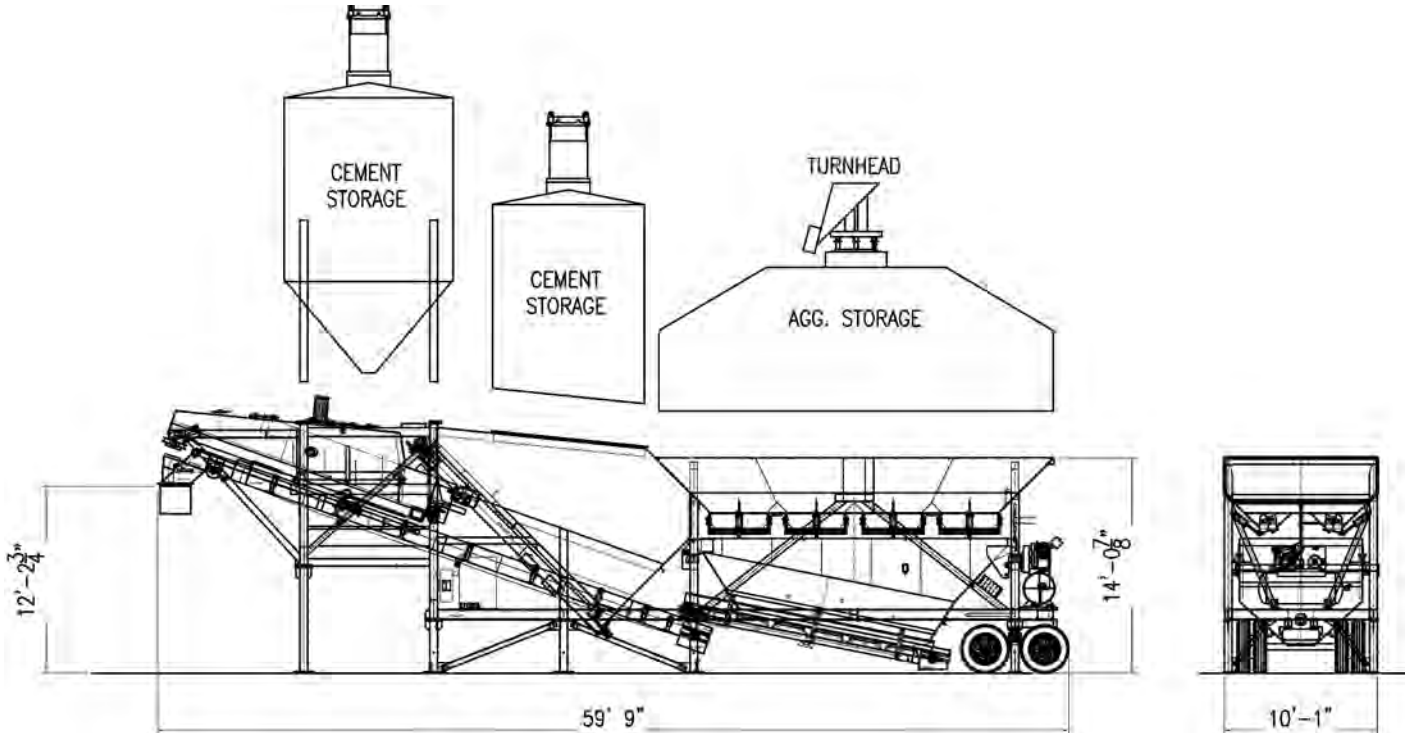

## SPECIFICATIONS

### PRODUCTION CAPACITY:

Theoretical Cycle Time – 2.5 to 3 minutes

### BATCHER CAPACITY:

Aggregate – 1 to 12 cubic yards (1 to 9.2 cubic meters)

Cement – 1 to 12 cubic yards (1 to 9.2 cubic meters)

Scales – Direct load cells

### AGGREGATE BATCHER CONVEYOR:

30" wide (762 mm), 10 horsepower drive. Optional 15 horsepower drive

### AGGREGATE DISCHARGE CONVEYOR:

30" wide (762 mm), 10 horsepower drive. Optional 36" (914 mm), 15 horsepower

### CEMENT BATCHER RECIRCULATING SCREW:

14" diameter (360 mm), 15 horsepower

Optional 18" diameter (460 mm), 20 horsepower

### CEMENT FEEDER SCREWS:

Two 9" diameter (230 mm), 15 horsepower drive. Optional 12" diameter (300 mm), 20 horsepower.

### CEMENT AERATION:

5 horsepower, high volume, low pressure blower.

### HIGH PRESSURE AIR COMPRESSOR:

10 horsepower, 120 gallon (0.45 cubic meters). Optional 15 or 20 horsepower, 120 gallon (0.45 cubic meters).

### ELECTRICAL:

460 volt, 3-phase with 120 VAC transformer for control voltage. All motors are TEFC. All motor circuit wiring protected by individual circuit breakers. Electrical components housed in NEMA steel enclosures. Wiring in conduit.

### BATCH CONTROL SYSTEM:

Semi-automatic cut-off of cement by presets on digital readouts. Push-button for electric over air on gates. Optional fully automatic computerized batch control system.

### WATER METER:

3" diameter (77 mm) with up to 500 gallons (1,740 liters) per minute.

### TRANSPORTATION SYSTEM:

Rear-mounted 36,000 lb. (16,330 kg) capacity tandem axle with eight (8) 295/75R 22.5 tires, wheels, air brakes heavy duty spring suspension, tail and brake lights, and fifth wheel rub plate with king pin.

### STORAGE BIN CAPACITIES:

AGGREGATE	HEAPED VOLUME
	46 to 86 cubic yards
	35 to 65 cubic meters
CEMENT I	GROSS VOLUME
	1,000 to 2,100 cubic feet
	28 to 59 cubic meters
CEMENT II	GROSS VOLUME
	1,600 to 2,260 cubic feet
	45 to 64 cubic meters

### DIMENSIONS:

Towing length.....	52'5" (15,977 mm)
Towing height.....	14'4" (4,369 mm)
Towing width.....	10'1" (3,073 mm)
Empty weight, total.....	44,000 lbs. (19,958 kg)

### SHIPPING DIMENSIONS:

Length .....	61'0" (18,593 mm)
Height .....	14'4" (4,369 mm)
Width .....	10'1" (3,073 mm)
Shipping volume.....	8,813 cubic feet (250 cubic meters)

# LO-PRO® Model 327

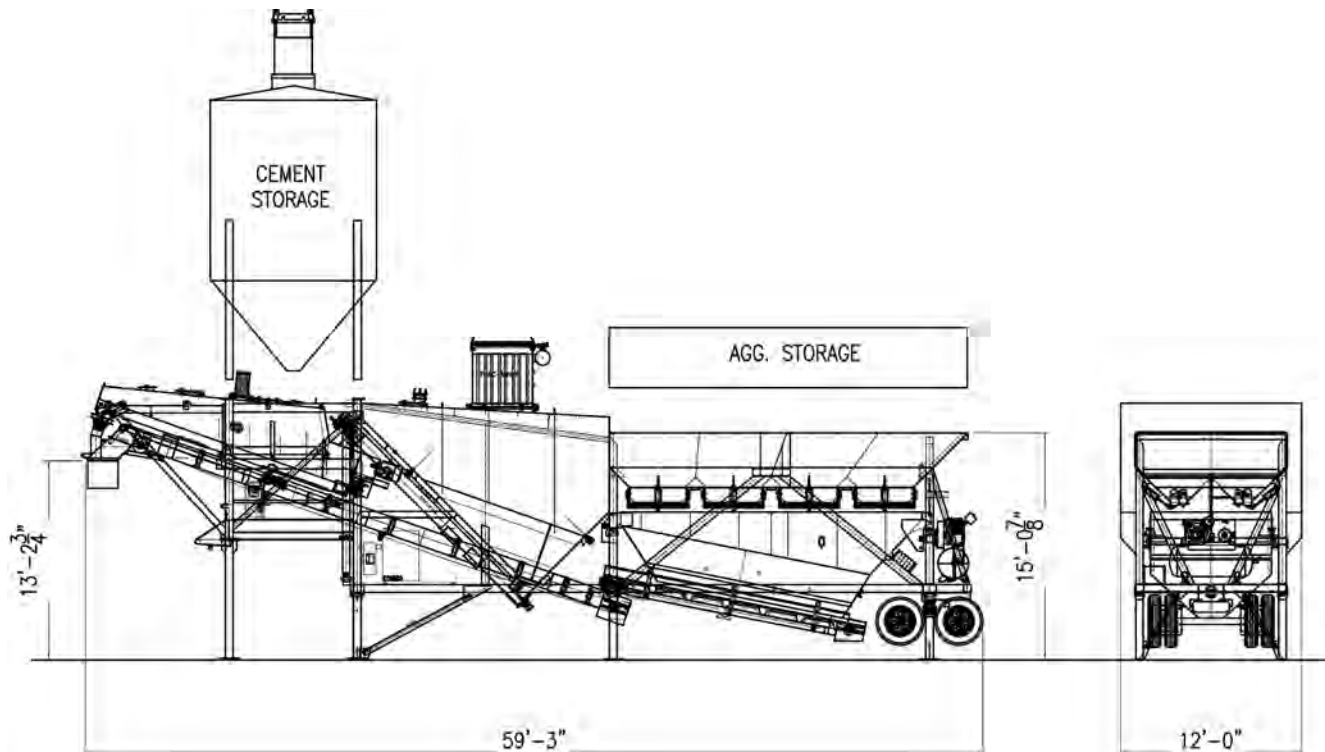

## SPECIFICATIONS

### PRODUCTION CAPACITY:

Theoretical Cycle Time – 2.5 to 3 minutes

### BATCHER CAPACITY:

Aggregate – 1 to 12 cubic yards (1 to 9.2 cubic meters)

Cement – 1 to 12 cubic yards (1 to 9.2 cubic meters)

Scales – Direct load cells

### AGGREGATE BATCHER CONVEYOR:

30" wide (762 mm), 10 horsepower drive. Optional 15 horsepower drive.

### AGGREGATE DISCHARGE CONVEYOR:

30" wide (762 mm), 35° trough with 10 horsepower drive. Optional 36" (914 mm), 15 horsepower

### CEMENT BATCHER BLENDING SCREW:

14" diameter (360 mm), 15 horsepower. Optional 18" diameter (460 mm), 20 or 25 horsepower.

### CEMENT FEEDER SCREWS:

Two 9" diameter (230 mm), 15 horsepower drive. Optional 12" diameter (300 mm), 20 horsepower drive.

### CEMENT AERATION:

5 horsepower, high volume, low pressure blowers.

### HIGH PRESSURE AIR COMPRESSOR:

10 horsepower, 120 gallon (0.45 cubic meters). Optional 15 or 20 horsepower, 120 gallon (0.45 cubic meters).

### ELECTRICAL:

460 volt, 3-phase with 120 VAC transformer for control voltage. All motors are TEFC. All motor circuit wiring protected by individual circuit breakers. Electrical components housed in NEMA steel enclosures. Wiring in conduit.

### BATCH CONTROL SYSTEM:

Semi-automatic cut-off of cement by presets on digital readouts. Push-button for electric over air on gates. Optional fully automatic computerized batch control system.

### WATER METER:

3" diameter (77 mm) with up to 500 gallons (1,740 liters) per minute.

### TRANSPORTATION SYSTEM:

Rear-mounted tandem axle with eight (8) 295/75R 22.5 tires, wheels, air brakes, heavy duty spring suspension, tail and brake lights, and fifth wheel rub plate with king pin.

### STORAGE BIN CAPACITIES:

AGGREGATE	HEAPED VOLUME	43 to 83 cubic yards
		33 to 63 cubic meters
CEMENT I	GROSS VOLUME	1,308 cubic feet
		37 cubic meters
CEMENT II	GROSS VOLUME	1,600 to 2,260 cubic feet
		45 to 64 cubic meters

### DIMENSIONS:

Towing length.....	52'5" (15,977 mm)
Towing height.....	14'4" (4,369 mm)
Towing width.....	12'0" (3,658 mm)
Empty weight, total.....	44,000 lbs. (19,958 kg)

### SHIPPING DIMENSIONS:

Length .....	61'0" (18,593 mm)
Height .....	14'4" (4,369 mm)
Width .....	12'0" (3,658 mm)
Shipping volume.....	10,490 cubic feet (297 cubic meters)



# LO-PRO® Model 327CM

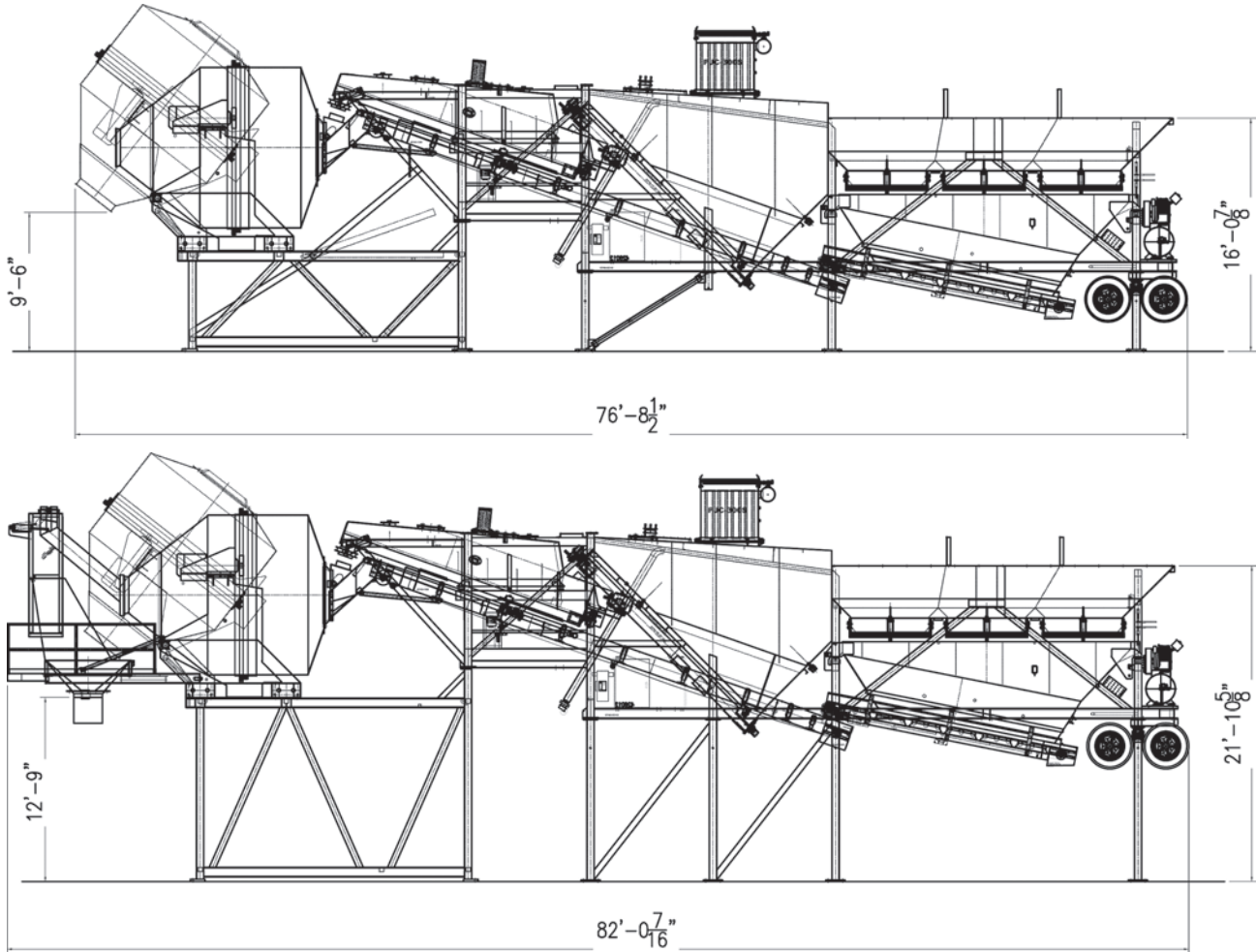

## SPECIFICATIONS

### PRODUCTION CAPACITY:

Theoretical Cycle Time – 2.5 to 3 minutes

### BATCHER CAPACITY:

Aggregate – 1 to 12 cubic yards (1 to 9.2 cubic meters)

Cement – 1 to 12 cubic yards (1 to 9.2 cubic meters)

Scales – Direct load cells

### AGGREGATE BATCHER CONVEYOR:

36" wide (914 mm), 20 horsepower drive.

### AGGREGATE DISCHARGE CONVEYOR:

36" wide (914 mm), 45° trough with 30 horsepower drive.

### CEMENT BATCHER BLENDING SCREW:

18" diameter (457 mm), 25 horsepower.

### CEMENT FEEDER SCREWS:

Two 12" diameter (300 mm), 20 horsepower drive. Optional 9" diameter (228 mm), 15 horsepower drive.

### CEMENT AERATION:

5 horsepower, high volume, low pressure blowers.

### HIGH PRESSURE AIR COMPRESSOR:

10 horsepower, 120 gallon (0.45 cubic meters). Optional 15 or 20 horsepower, 120 gallon (0.45 cubic meters).

### ELECTRICAL:

460 volt, 3-phase with 120 VAC transformer for control voltage. All motors are TEFC. All motor circuit wiring protected by individual circuit breakers. Electrical components housed in NEMA steel enclosures. Wiring in conduit.

### BATCH CONTROL SYSTEM:

Semi-automatic cut-off of cement by presets on digital readouts. Push-button for electric over air on gates. Optional fully automatic computerized batch control system.

### WATER METER:

3" diameter (77 mm) with up to 500 gallons (1,740 liters) per minute.

### TRANSPORTATION SYSTEM:

Rear-mounted tandem axle with eight (8) 295/75R 22.5 tires, wheels, air brakes, heavy duty spring suspension, tail and brake lights, and fifth wheel rub plate with king pin.

### STORAGE BIN CAPACITIES:

AGGREGATE	HEAPED VOLUME
	43 to 83 cubic yards
	33 to 63 cubic meters
CEMENT I	GROSS VOLUME
	1,308 cubic feet
	37 cubic meters
CEMENT II	GROSS VOLUME
	1,600 to 2,260 cubic feet
	45 to 64 cubic meters

# LO-PRO® Model 427

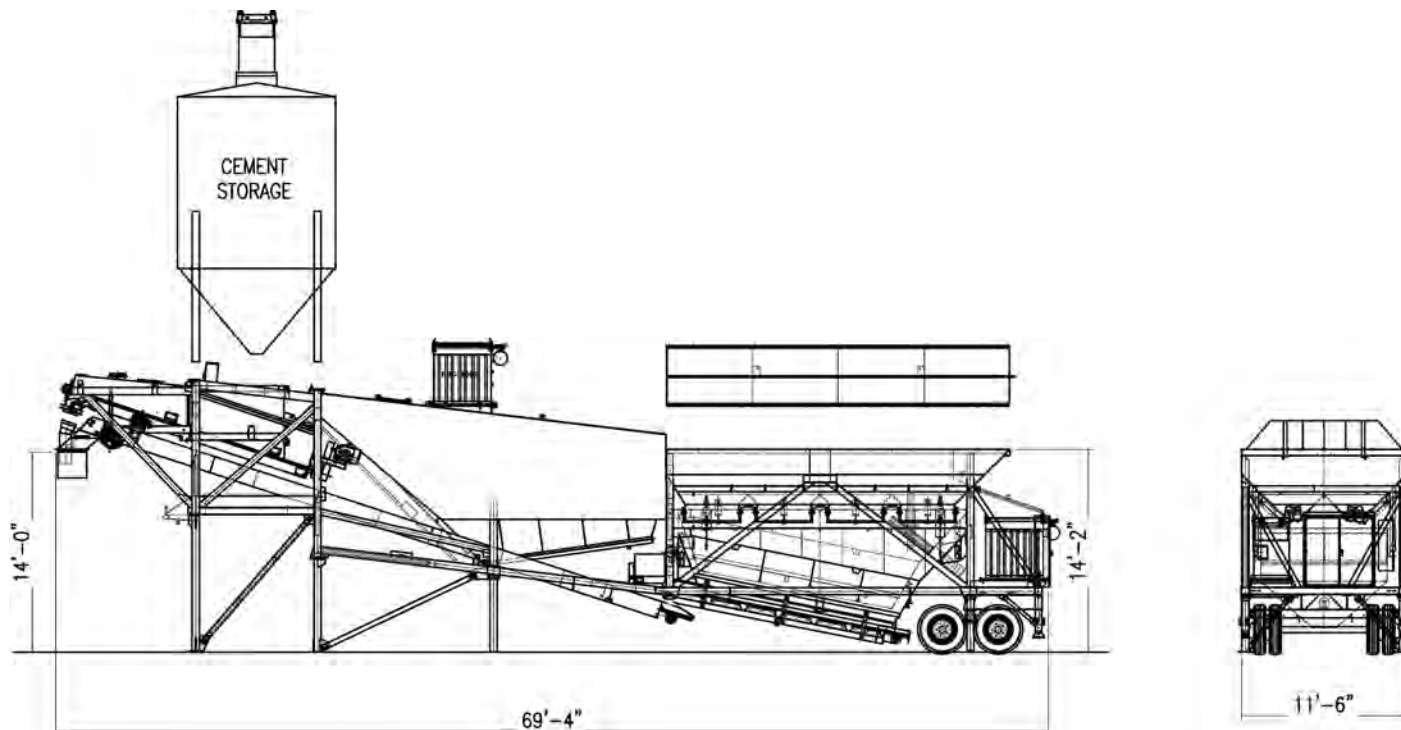

## SPECIFICATIONS

### PRODUCTION CAPACITY:

Theoretical Cycle Time – 2.5 to 3 minutes

### BATCHER CAPACITY:

Aggregate – 1 to 12 cubic yards (1 to 9.2 cubic meters)

Cement – 1 to 12 cubic yards (1 to 9.2 cubic meters)

Scales – Direct load cells

### AGGREGATE BATCHER CONVEYOR:

30" wide (762 mm), 10 horsepower drive. Optional 15 horsepower drive.

### AGGREGATE DISCHARGE CONVEYOR:

30" wide (762 mm), 35° trough with 10 horsepower drive. Optional 36" (914 mm), 15 horsepower

### CEMENT BATCHER BLENDING SCREW:

14" diameter (360 mm), 15 horsepower. Optional 18" diameter (460 mm), 20 or 25 horsepower.

### CEMENT FEEDER SCREWS:

Two 9" diameter (230 mm), 15 horsepower drive. Optional 12" diameter (300 mm), 20 horsepower drive.

### CEMENT AERATION:

5 and 7 horsepower, high volume, low pressure blowers.

### HIGH PRESSURE AIR COMPRESSOR:

10 horsepower, 120 gallon (0.45 cubic meters). Optional 15, 20, 25, or 30 horsepower, 120 gallon (0.45 cubic meters).

### ELECTRICAL:

460 volt, 3-phase with 120 VAC transformer for control voltage. All motors are TEFC. All motor circuit wiring protected by individual circuit breakers. Electrical components housed in NEMA steel enclosures. Wiring in conduit.

### BATCH CONTROL SYSTEM:

Semi-automatic cut-off of cement by presets on digital readouts. Push-button for electric over air on gates. Optional fully automatic computerized batch control system.

### WATER METER:

3" diameter (77 mm) with up to 500 gallons (1,740 liters) per minute.

### TRANSPORTATION SYSTEM:

Rear-mounted tandem axle with eight (8) 295/75R 22.5 tires, wheels, air brakes, heavy duty spring suspension, tail and brake lights, and fifth wheel rub plate with king pin.

### STORAGE BIN CAPACITIES:

AGGREGATE	HEAPED VOLUME
	50 to 90 cubic yards
	38 to 68 cubic meters
CEMENT I	GROSS VOLUME
	1,708 cubic feet
	47.5 cubic meters
CEMENT II	GROSS VOLUME
	1,600 to 3,060 cubic feet
	45 to 85 cubic meters

### DIMENSIONS:

Towing length.....	60'0" (18,000 mm)
Towing height.....	14'4" (4,369 mm)
Towing width.....	11'6" (3,450 mm)
Empty weight, total.....	55,000 lbs. (24,750 kg)

### SHIPPING DIMENSIONS:

Length .....	70'0" (21,336 mm)
Height .....	14'4" (4,369 mm)
Width .....	11'6" (3,450 mm)
Shipping volume.....	11,536 cubic feet (326 cubic meters)

# LO-PRO® Model 427CM

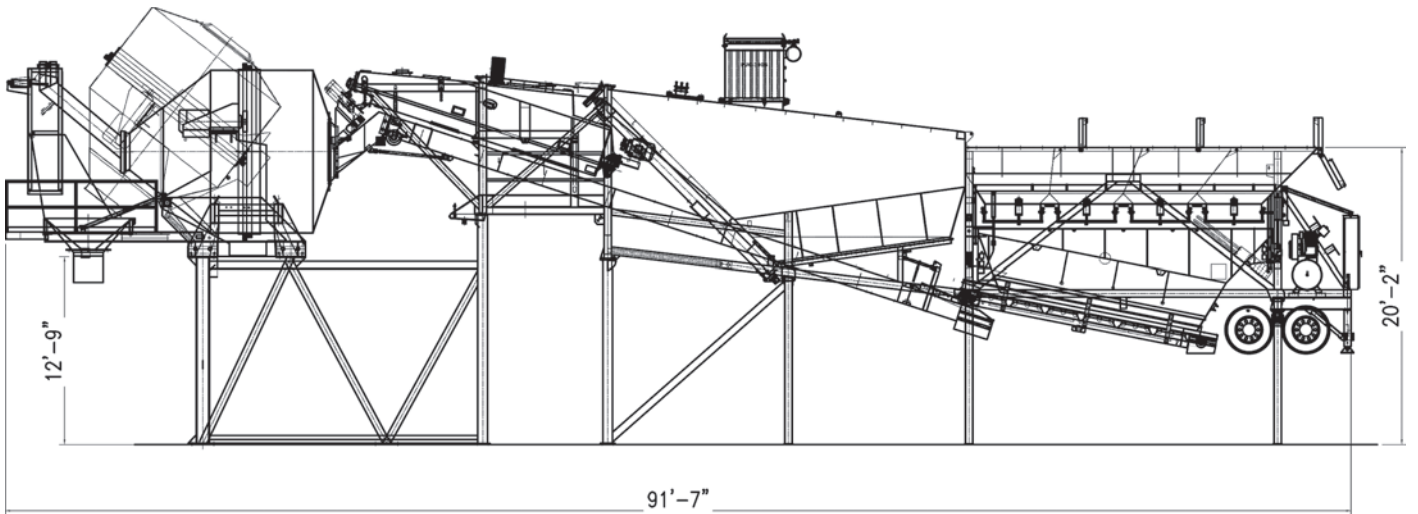
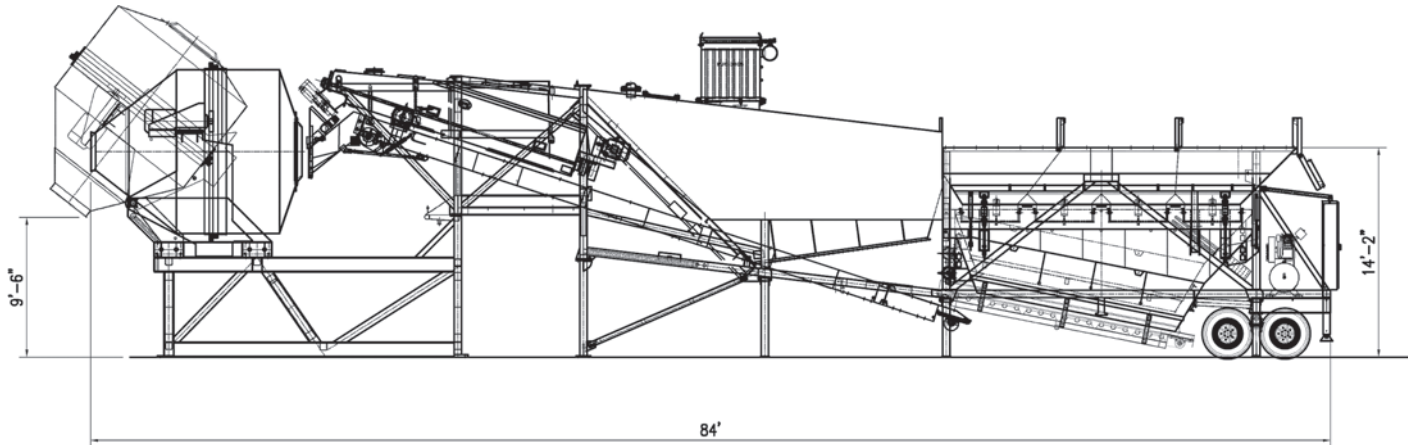

## SPECIFICATIONS

### PRODUCTION CAPACITY:

Theoretical Cycle Time – 2.5 to 3 minutes

### BATCHER CAPACITY:

Aggregate – 1 to 12 cubic yards (1 to 9.2 cubic meters)

Cement – 1 to 12 cubic yards (1 to 9.2 cubic meters)

Scales – Direct load cells

### AGGREGATE BATCHER CONVEYOR:

36" wide (914 mm), 20 horsepower drive. Optional 25 horsepower drive. Optional 48" wide (1,219 mm), 40 horsepower drive.

### AGGREGATE DISCHARGE CONVEYOR:

36" wide (914 mm), 45° trough with 40 horsepower drive. Optional 42" (1,066 mm), 35° trough with dual 25 horsepower drives. Optional 48" wide (1,219 mm), 45° trough with dual 40 horsepower drives.

### CEMENT BATCHER BLENDING SCREW:

18" diameter (457 mm), 25 horsepower. Optional 20" diameter (508 mm), 30 horsepower.

### CEMENT FEEDER SCREWS:

Two 12" diameter (300 mm), 20 horsepower drive. Optional 14" diameter (355 mm), 40 horsepower drive.

### CEMENT AERATION:

5 and 7 horsepower, high volume, low pressure blowers.

### HIGH PRESSURE AIR COMPRESSOR:

10 horsepower, 120 gallon (0.45 cubic meters). Optional 15, 20, 25, or 30 horsepower, 120 gallon (0.45 cubic meters).

### ELECTRICAL:

460 volt, 3-phase with 120 VAC transformer for control voltage. All motors are TEFC. All motor circuit wiring protected by individual circuit breakers. Electrical components housed in NEMA steel enclosures. Wiring in conduit.

### BATCH CONTROL SYSTEM:

Semi-automatic cut-off of cement by presets on digital readouts. Push-button for electric over air on gates. Optional fully automatic computerized batch control system.

### WATER METER:

3" diameter (77 mm) with up to 500 gallons (1,740 liters) per minute.

### TRANSPORTATION SYSTEM:

Rear-mounted tandem axle with eight (8) 295/75R 22.5 tires, wheels, air brakes, heavy duty spring suspension, tail and brake lights, and fifth wheel rub plate with king pin.

### STORAGE BIN CAPACITIES:

AGGREGATE	HEAPED VOLUME 50 to 90 cubic yards 38 to 68 cubic meters
-----------	--

CEMENT I	GROSS VOLUME 1,708 cubic feet 47.5 cubic meters
----------	---

CEMENT II	GROSS VOLUME 1,600 to 3,060 cubic feet 45 to 85 cubic meters
-----------	--

